



L83 MK2+L83S MK2 Column System

L83 MK2+L83S MK2 system is a compact multi-purpose active DSP column system consisting of a passive full-range column speaker L83 MK2 and an active DSP controlled dual 12" subwoofer L83S MK2.

L83 MK2 passive full-range column speaker is with 8pcs 3" full-range drivers and 2pcs 1" customized drivers. The drivers are designed with sophisticated measurement and arranged elaborately by physical calibration technology Phyca™ to improve vertical acoustic beam coverage. The ETE™ waveguide system developed by Audiocenter forms cylindrical wave, then couples continually, working together with customized horn design to realize the perfect joint of frequency response, which provides the accurate horizontal coverage and ensures the well-balanced, clean and clear sound. L83 MK2 can meet the reinforcement application in different venues and complex space.

L83S MK2 is an active DSP controlled compact subwoofer with 2pcs 12" customized drivers and Class D amplifier module. The system works efficiently and has built-in Bluetooth that supports multiple signal inputs.

L83S MK2 has been carefully tested. With elaborate acoustic design, innovative FTF™ LF driver design and extensive testing, the cabinet is with three-order band-pass filter. By coupling the system continually and overlaying the resonances, the LF efficiency is improved significantly.

L83 MK2+L83S MK2 is a plug and play column system with easy set up. The presets are made with a lot of testing. The system can be put in various applications.

L83 MK2

L83S MK2

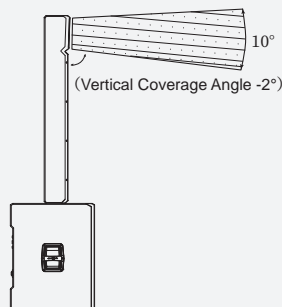

SUGGESTED APPLICATION



Ball room



House of worship



Museum



Lecture



DJ



Gym



Restaurant

SPECIFICATION

Type	Active DSP-controlled Column Speaker System
Frequency Response(-10dB)	40Hz-20kHz
Horizontal Coverage	110°
Vertical Coverage	10°
Maximum Calculated SPL/1M(Continuous/Peak):	129dB/135dB
HF	Customized driver, 2pcs 1" drivers
LF	Customized driver, 8pcs 3" drivers
Subwoofer	Customized driver, 2pcs 12" driver
DSP	
Processor	96kHz signal sampling frequency
Presets	L83 MK2, L65 MK2, T4L
Class D amplifier	
Power(RMS standards)	2000W
Peak Power	4000W
Frequency Response	20Hz-20kHz(±0.5dB)
Intermodulation Distortion	<0.05%
Total Harmonic Distortion	<0.05%
Cooling System	Cooling with fans, air convection
Protection	DC protection, short circuit protection, overheat protection, input overload protection, output overload protection, soft startup protection, overvoltage protection, undervoltage protection
Signal Input	Combo (female XLR & Mono jack 6.35), Stereo Bluetooth
Signal Output	Male XLR
Amplifier Output Link L83 MK2	Speakon 4pin
Column Input Link L83S MK2	Speakon 4pin
Power Input	IEC power connector
AC Power Operating Range	100V-130V~ or 220V-240V~ (±10%,50/60Hz)
Power consumption (1/8 output power)	167W
CABINET	
Cabinet Material	CNC made of excellent wood
Cabinet Color	Black is the default color. Contact Audiocenter for customization
Grille	Iron mesh
Handles	L83S MK2 2 side
L83S MK2 Pole Mount	M20 base Φ35mm
Speaker Dimension(WxHxD)	
L83 MK2	135x1200x165mm
L83S MK2	374x690x538mm
Carton Dimensions (WxHxD)	
L83 MK2	1302x229x220mm
L83S MK2	467x625x780mm
Net Weight	
L83 MK2	10.5kg
L83S MK2	34.0kg
Shipping Weight	
L83 MK2	14.0kg
L83S MK2	38.0kg

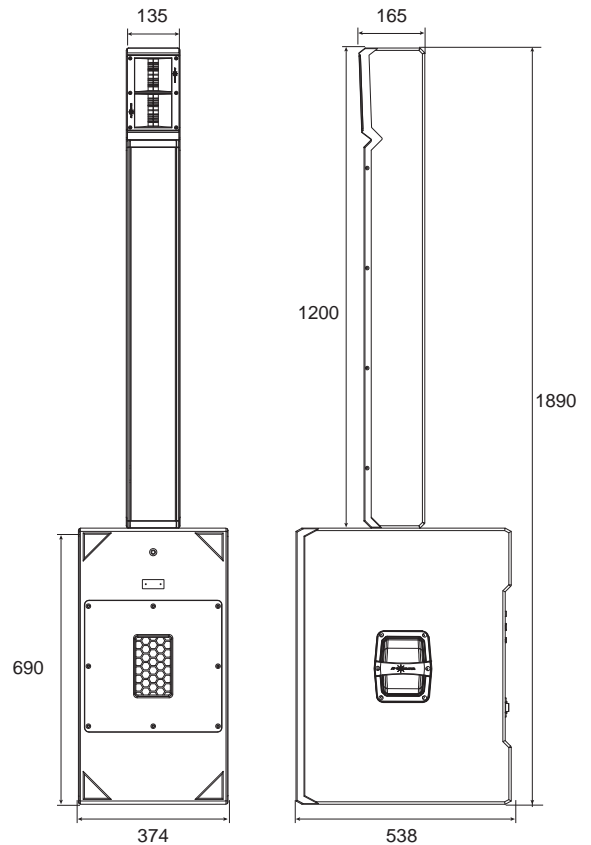

BACK PANEL

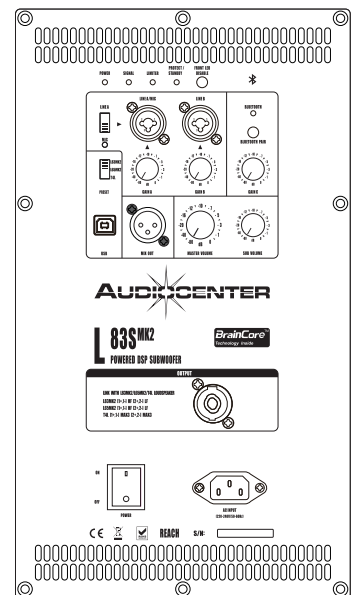
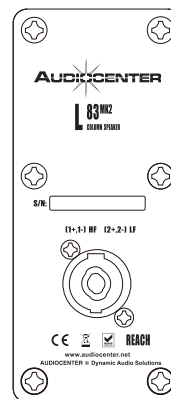

ACCESSORIES

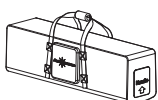

Hand bag
For 2 pcs L83 MK2

L83S MK2 Protection bag
(with wheel)